



DRUID

INTRODUCTION	03
GEOMETRY	04
FRAME KIT	05
DRUID XO	06
DRUID GX-FX	07
DRUID GX-RS	08

DREADNOUGHT

INTRODUCTION	09
GEOMETRY	10
FRAME KIT	11
DREADNOUGHT XO	12
DRUID GX	13

TECHNOLOGY

TRIFECTA	14
ONE RIDE	15

DRUID

The second iteration of the genre-melting Druid sees a ground-up frame re-imagination that reaffirms its position as a class leader. Every trait and characteristic you know and love about the existing Druid is at the core of V2. It just looks a little different and rides even better.

The Druid is the ultimate wolf in sheep's clothing. Its high pivot Trifecta suspension platform defies logic, generating predictable traction and playful pop simultaneously while offering an otherworldly ability to devour chunky terrain. With geometry that effortlessly balances stability and agility, the Druid is equally at home hammering out trail rides after work, crushing epic alpine traverses, and blasting weekend shuttle laps.

All over the mountain, the more you ask of the Druid, the more you get.

INTENDED USE

Trail / All Mountain

SUSPENSION

130mm Rear / 150mm Front

WHEEL SIZE

Full 29er or Mixed (MX)

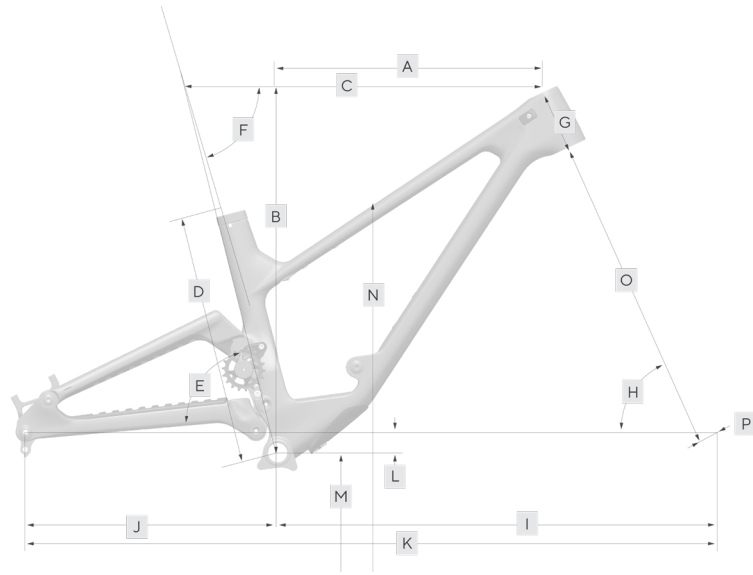

	150 mm FORK		S1		S2		S3		S4	
	MX	29"	MX	29"	MX	29"	MX	29"	MX	29"
A REACH	435	440	455	460	475	480	495	500		
B STACK	614	610	627	624	641	637	654	651		
C HORIZONTAL TOP TUBE LENGTH	582	581	605	604	628	627	651	650		
D SEAT TUBE LENGTH	400	400	420	420	440	440	470	470		
E SEAT TUBE ANGLE (effective)	76.6	77	76.6	77	76.6	77	76.6	77		
F SEAT TUBE ANGLE (actual)	73.4	73.8	75.1	76.6	76.6	77.0	76.6	77.0		
G HEAD TUBE LENGTH	90	90	105	105	120	120	135	135		
H HEAD TUBE ANGLE	64.5	65.0	64.5	65.0	64.5	65.0	64.5	65.0		
I FRONT CENTER	754	754	781	781	807	807	833	833		
J REAR CENTER	423	423	437	437	452	452	466	466		
K WHEELBASE	1177	1177	1218	1218	1259	1259	1300	1299		
L BB DROP	-29	-35	-29	-35	-29	-35	-29	-35		
M BB HEIGHT*	332	337	332	337	332	337	332	337		
N STAND OVER	720	720	725	725	728	728	730	730		
O FORK LENGTH	561	561	561	561	561	561	561	561		
P FORK OFFSET	42	42	42	42	42	42	42	42		



FORBIDDEN

DRUID FRAME KIT

MSRP €3,999

FRAME



SPECIFICATIONS

DRUID FULL CARBON . 130MM TRAVEL

FORK	N/A
REAR SHOCK	Rock Shox Super Deluxe Ultimate
HEADSET	N/A
GRIPS	N/A
HANDLE BAR	N/A
STEM	N/A
SEAT POST	N/A
SEAT POST REMOTE	N/A
SEAT POST CLAMP	Forbidden
SADDLE	N/A
FRONT BRAKE	N/A
FRONT BRAKE ROTOR	N/A
REAR BRAKE	N/A
REAR BRAKE ROTOR	N/A
SHIFTER REAR	N/A
REAR DERAILLEUR	N/A
CASSETTE	N/A
CHAIN	N/A
CRANKSET	N/A
CHAIN TENSIONER	Forbidden Idler Pulley with Custom Chainguide
BOTTOM BRACKET	N/A
FRONT HUB	N/A
FRONT HUB SKEWER	N/A
REAR HUB	N/A
REAR HUB SKEWER	Burgtec 180 x 1.0mm Axle UDH
SPOKES/NIPPLES	N/A
RIMS	N/A
FRONT TIRE	N/A
REAR TIRE	N/A
EXTRAS	

FORBIDDEN

DRUID XO

MSRP €10,599

XO



SPECIFICATIONS

DRUID FULL CARBON . 130MM TRAVEL

FORK	Rock Shox Lyrik Ultimate
REAR SHOCK	Rock Shox Super Deluxe Ultimate
HEADSET	Cane Creek Hellbender 70
GRIPS	Burgtec Bartender Pro
HANDLE BAR	Burgtec Ride Wide Enduro Alloy // Ride High Alloy
STEM	Burgtec OE MK3 Enduro Stem - 42.5mm
SEAT POST	OneUp Dropper Post
SEAT POST REMOTE	OneUp MMX UFT Lever
SEAT POST CLAMP	Forbidden
SADDLE	Fizik Terra Alpaca X5
FRONT BRAKE	SRAM Code Stealth Ultimate 4-Piston
FRONT BRAKE ROTOR	SRAM HS2 - 180mm
REAR BRAKE	SRAM Code Stealth Ultimate 4-Piston
REAR BRAKE ROTOR	SRAM HS2 - 180mm
SHIFTER REAR	AXS POD RIGHT W/MMX
REAR DERAILLEUR	SRAM XO AXS 12speed
CASSETTE	SRAM XS-1295 10-52T 12speed
CHAIN	XO - 12speed - Includes Powerlock
CRANKSET	SRAM XO Eagle 32T - 165mm
CHAIN TENSIONER	Forbidden Idler Pulley with Custom Chainguide
BOTTOM BRACKET	SRAM DUB Threaded BSA Wide
FRONT HUB	Crankbrothers Synthesis Enduro i9 1/1 Front Hub
FRONT HUB SKEWER	Maxle Stealth
REAR HUB	Crankbrothers Synthesis Enduro i9 1/1 Rear Hub
REAR HUB SKEWER	Burgtec 180 x 1.0mm Axle UDH
SPOKES/NIPPLES	Sapim CX Ray (fr) / CX Sprint (rr)
RIMS	Crankbrothers Synthesis 11 - Carbon
FRONT TIRE	Maxxis Assegai 29"x2.5" 3C Maxx Terra - EXO
REAR TIRE	Maxxis DHR11 Wide Trail - 3C Maxx Terra - EXO+
EXTRAS	Stans Sealant - 200ml SRAM AXS EP Powerpack 1 Battery



FORBIDDEN

DRUID GX-FX

MSRP €8,599

GX - FX



SPECIFICATIONS

DRUID FULL CARBON . 130MM TRAVEL

FORK	Fox 36 FLOAT - Performance-Elite
REAR SHOCK	2024, FLOAT X, P-Se, A, 2pos-Adj, Trunnion, Evol LV, Forbidden, Druid, 185, 55, 0.3 Spacer, CL, PRMAL001, Rezi LMB3, Standard, Neutral Logo
HEADSET	Cane Creek 40
GRIPS	Burgtec Bartender Pro
HANDLE BAR	Burgtec Ride Wide Enduro Alloy // Ride High Alloy
STEM	Burgtec OE MK3 Enduro Stem - 42.5mm
SEAT POST	OneUp Dropper Post
SEAT POST REMOTE	OneUp MMX UFT Lever
SEAT POST CLAMP	Forbidden
SADDLE	Fizik Terra Alpaca X5
FRONT BRAKE	SRAM Code Stealth Silver 4-Piston
FRONT BRAKE ROTOR	SRAM Centerline - 180mm
REAR BRAKE	SRAM Code Stealth Silver 4-Piston
REAR BRAKE ROTOR	SRAM Centerline - 180mm
SHIFTER REAR	AXS POD RIGHT W/MMX
REAR DERAILLEUR	SRAM GX AXS 12speed
CASSETTE	SRAM GX 10-52T 12speed
CHAIN	GX - 12speed - Includes Powerlock
CRANKSET	SRAM GX Eagle 32T - 165mm
CHAIN TENSIONER	Forbidden Idler Pulley with Custom Chainguide
BOTTOM BRACKET	SRAM DUB Threaded BSA Wide
FRONT HUB	Crankbrothers Synthesis Enduro i9 1/1 Front Hub
FRONT HUB SKEWER	Kabolt X
REAR HUB	Crankbrothers Synthesis Enduro i9 1/1 Rear Hub
REAR HUB SKEWER	Burgtec 180 x 1.0mm Axle UDH
SPOKES/NIPPLES	Sapim D-Light
RIMS	Crankbrothers Synthesis Enduro - Alloy
FRONT TIRE	Maxxis Assegai 29"x2.5" 3C Maxx Terra - EXO
REAR TIRE	Maxxis DHR11 Wide Trail - 3C Maxx Terra - EXO+
EXTRAS	Stans Sealant - 200ml SRAM AXS EP Powerpack 1 Battery



FORBIDDEN

DRUID GX-RS

MSRP €7,499

GX - RS



SPECIFICATIONS

DRUID FULL CARBON . 130MM TRAVEL

FORK	Rock Shox Lyrik Select
REAR SHOCK	Rock Shox Deluxe Select+
HEADSET	Cane Creek 40
GRIPS	Race Face Half Nelson
HANDLE BAR	Raceface Aeffect R
STEM	Raceface Aeffect R
SEAT POST	OneUp Dropper Post
SEAT POST REMOTE	OneUp MMX UFT Lever
SEAT POST CLAMP	Forbidden
SADDLE	Fizik Terra Alpaca X5
FRONT BRAKE	SRAM Code Stealth 4-Piston
FRONT BRAKE ROTOR	SRAM Centerline - 180mm
REAR BRAKE	SRAM Code Stealth 4-Piston
REAR BRAKE ROTOR	SRAM Centerline - 180mm
SHIFTER REAR	AXS POD RIGHT W/MMX
REAR DERAILLEUR	SRAM GX AXS 12speed
CASSETTE	SRAM GX 10-52T 12speed
CHAIN	GX - 12speed - Includes Powerlock
CRANKSET	SRAM GX Eagle 32T - 165mm
CHAIN TENSIONER	Forbidden Idler Pulley with Custom Chainguide
BOTTOM BRACKET	SRAM DUB Threaded BSA Wide
FRONT HUB	Crankbrothers Synthesis Enduro Std
FRONT HUB SKEWER	Maxle Stealth
REAR HUB	Crankbrothers Synthesis Enduro Std
REAR HUB SKEWER	Burgtec 180 x 1.0mm Axle UDH
SPOKES/NIPPLES	Sapim Race
RIMS	Crankbrothers Synthesis Enduro - Alloy
FRONT TIRE	Maxxis ASSEGAI 2.5 F120 3G/EXO+/TR OE FB
REAR TIRE	Maxxis DHR11 2.4 3T/EXO+/TR OE
EXTRAS	Stans Sealant - 200ml SRAM AXS EP Powerpack 1 Battery



DREADNOUGHT

Whether you're on the start line or in line to shred your local spot, you'll be equipped to blast any jump line, rock garden, and rut track in your path aboard the Forbidden Dreadnought. Bigger, burlier and ready for anything. This mountain taming bruiser of a bicycle knows no bound, and neither will you. We expanded our category defying high pivot design from the Druid and applied it to a platform built to handle the extremes. A DH bike in all but the small print. Dreadnought is ready for the rowdiest backcountry lines, the steepest race stages and the shadiest gaps in the bike park. The only thing this bike needs is a pilot ready to feed it a non-stop diet of rough and rowdy terrain.

Bring the big guns, bring the Dreadnought and fear nothing.

INTENDED USE

Enduro / Bikepark

SUSPENSION

154mm Rear / 170mm Front

WHEEL SIZE

Full 29er or Mixed (MX)

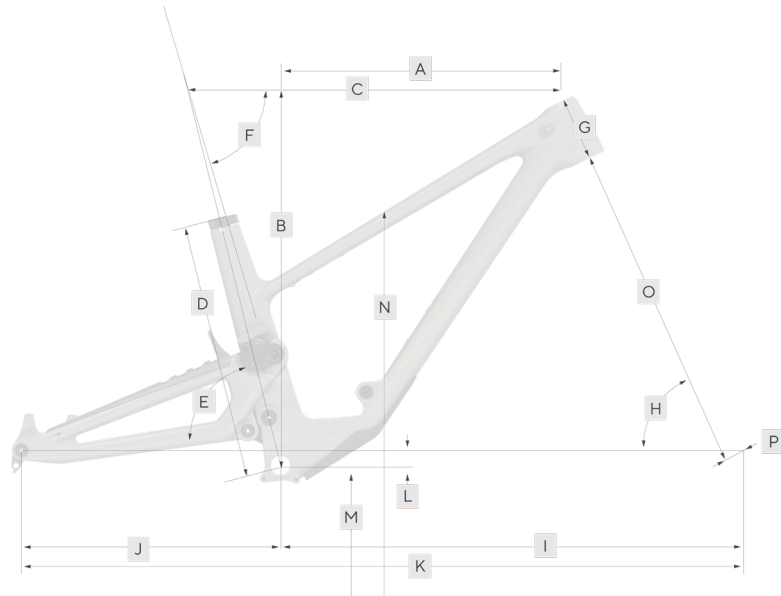

		170 mm FORK		S		M		L		XL	
		MX	29"	MX	29"	MX	29"	MX	29"		
A	REACH	435	440	457	462	479	484	501	506		
B	STACK	615	612	625	621	634	630	643	639		
C	HORIZONTAL TOP TUBE LENGTH	594	593	618	617	642	641	666	665		
D	SEAT TUBE LENGTH	400	400	420	420	450	450	490	490		
E	SEAT TUBE ANGLE (effective)	75.5	76	75.6	76	75.6	76	75.6	76		
F	SEAT TUBE ANGLE (actual)	72.6	73.0	74.3	74.7	75.7	76.1	76.7	77.1		
G	HEAD TUBE LENGTH	90	90	100	100	110	110	120	120		
H	HEAD TUBE ANGLE	63.0	63.5	63.1	63.5	63.1	63.5	63.1	63.5		
I	FRONT CENTER	781	781	808	808	834	834	861	861		
J	REAR CENTER	418	422	432	436	446	450	460	464		
K	WHEELBASE	1200	1203	1240	1244	1281	1284	1321	1325		
L	BB DROP	-19.9	-26	-19.9	-26	-19.9	-26	-19.9	-26		
M	BB HEIGHT*	340.7	347	340.7	347	340.7	347	340.7	347		
N	STAND OVER	721	721	721	721	727	727	733	733		
O	FORK LENGTH	583.71	583.71	583.71	583.71	583.71	583.71	583.71	583.71		
P	FORK OFFSET	44	44	44	44	44	44	44	44		



FORBIDDEN

DREADNOUGHT FRAME KIT

MSRP €3,999

FRAME



SPECIFICATIONS

DREADNOUGHT V1 FULL CARBON - 154MM TRAVEL

FORK	N/A
REAR SHOCK	Rock Shox Super Deluxe Ultimate
HEADSET	N/A
GRIPS	N/A
HANDLE BAR	N/A
STEM	N/A
SEAT POST	N/A
SEAT POST REMOTE	N/A
SEAT POST CLAMP	Forbidden
SADDLE	N/A
FRONT BRAKE	N/A
FRONT BRAKE ROTOR	N/A
REAR BRAKE	N/A
REAR BRAKE ROTOR	N/A
SHIFTER REAR	N/A
REAR DERAILLEUR	N/A
CASSETTE	N/A
CHAIN	N/A
CRANKSET	N/A
CHAIN TENSIONER	Forbidden Idler Pulley with e.13 Custom Chainguide
BOTTOM BRACKET	N/A
FRONT HUB	N/A
FRONT HUB SKEWER	N/A
REAR HUB	N/A
REAR HUB SKEWER	Burgtec 180 x 1.0mm Axle UDH
SPOKES/NIPPLES	N/A
RIMS	N/A
FRONT TIRE	N/A
REAR TIRE	N/A
EXTRAS	



FORBIDDEN

DREADNOUGHT XO

MSRP €9,599

XO



SPECIFICATIONS

DREADNOUGHT V1 FULL CARBON - 154MM TRAVEL

FORK	Rock Shox ZEB Ultimate
REAR SHOCK	Rock Shox Super Deluxe Ultimate
HEADSET	Cane Creek Hellbender 70
GRIPS	Burgtec Bartender Pro
HANDLE BAR	Burgtec Ride Wide Enduro Alloy // Ride High Alloy
STEM	Burgtec OE MK3 Enduro Stem - 42.5mm
SEAT POST	OneUp Dropper Post
SEAT POST REMOTE	OneUp MMX UFT Lever
SEAT POST CLAMP	Forbidden
SADDLE	Fizik Terra Alpaca X5
FRONT BRAKE	SRAM Code Stealth Ultimate 4-Piston
FRONT BRAKE ROTOR	SRAM HS2 - 200mm
REAR BRAKE	SRAM Code Stealth Ultimate 4-Piston
REAR BRAKE ROTOR	SRAM HS2 - 200mm
SHIFTER REAR	AXS RIGHT W/MMX
REAR DERAILLEUR	SRAM XO AXS 12speed
CASSETTE	SRAM XS-1295 10-52T 12speed
CHAIN	XO - 12speed - Includes Powerlock
CRANKSET	SRAM XO Eagle 32T - 165mm
CHAIN TENSIONER	Forbidden Idler Pulley with e.13 Custom Chainguide
BOTTOM BRACKET	SRAM DUB Threaded BSA Wide
FRONT HUB	Crankbrothers Synthesis Enduro i9 1/1 Front Hub
FRONT HUB SKEWER	Maxle Stealth
REAR HUB	Crankbrothers Synthesis Enduro i9 1/1 Rear Hub
REAR HUB SKEWER	Burgtec 180 x 1.0mm Axle UDH
SPOKES/NIPPLES	Sapim D-Light
RIMS	Crankbrothers Synthesis Enduro - Alloy
FRONT TIRE	Maxxis Assegai 29"x2.5" 3C Maxx Grip - EXO+
REAR TIRE	Maxxis DHR11 2.4 3T/DD/TR
EXTRAS	Stans Sealant - 200ml SRAM AXS EP Powerpack 1 Battery



FORBIDDEN

DREADNOUGHT GX

MSRP €8,599

GX



SPECIFICATIONS

DREADNOUGHT V1 FULL CARBON - 154MM TRAVEL

FORK	Rock Shox ZEB Select+
REAR SHOCK	Rock Shox Super Deluxe Ultimate
HEADSET	Cane Creek 40
GRIPS	Burgtec Bartender Pro
HANDLE BAR	Burgtec Ride Wide Enduro Alloy // Ride High Alloy
STEM	Burgtec OE MK3 Enduro Stem - 42.5mm
SEAT POST	OneUp Dropper Post
SEAT POST REMOTE	OneUp MMX UFT Lever
SEAT POST CLAMP	Forbidden
SADDLE	Fizik Terra Alpaca X5
FRONT BRAKE	SRAM Code RSC 4-Piston
FRONT BRAKE ROTOR	SRAM Centerline - 200mm
REAR BRAKE	SRAM Code RSC 4-Piston
REAR BRAKE ROTOR	SRAM Centerline - 200mm
SHIFTER REAR	AXS RIGHT W/MMX
REAR DERAILLEUR	SRAM GX AXS 12speed
CASSETTE	SRAM XS-1275 10-52T 12speed
CHAIN	GX - 12speed - Includes Powerlock
CRANKSET	SRAM GX Eagle 32T - 165mm
CHAIN TENSIONER	Forbidden Idler Pulley with e.13 Custom Chainguide
BOTTOM BRACKET	SRAM DUB Threaded BSA Wide
FRONT HUB	i9 1/1 Front Hub
FRONT HUB SKEWER	Maxle Stealth
REAR HUB	i9 1/1 Rear Hub
REAR HUB SKEWER	Burgtec 180 x 1.0mm Axle UDH
SPOKES/NIPPLES	Sapim D-Light
RIMS	Crankbrothers Synthesis Enduro - Alloy
FRONT TIRE	Maxxis Assegai 29"x2.5" 3C Maxx Grip - EXO+
REAR TIRE	Maxxis DHR11 2.4 3T/DD/TR
EXTRAS	Stans Sealant - 200ml SRAM AXS EP Powerpack 1 Battery





TRIFECTA



HIGH PIVOT



A suspension system with a high pivot point that results in a rearward axle path throughout its travel.

The rearward motion allows the rear wheel to move with, not against impacts, maintaining forward momentum through rough terrain.

The lengthening of the rear-center under compression stabilizes the chassis during bigger impacts.

Resultant weight bias is playful when high in the travel but inherently more composed when you need it the most.



RATE CONTROL



Our Rate Control Linkage is used to manipulate the leverage rate as the suspension compresses.

Supple off the top with a supportive mid-stroke that remains open enough to absorb repetitive hits with no harshness.

A further increase in the rate of change at the end of the stroke provides adequate bottom out resistance and a bottomless feeling.

The result is a bike that punches way above bikes with more millimetres on their spec sheet. A bike that generates grip and pop almost simultaneously with an otherworldly ability to devour big hits.



IDLER POSITION



The size and position of our idler pulleys are critical in delivering pedalling efficiency.

By carefully positioning the pulley, offset from the main pivot, we were able to fine-tune the anti-squat characteristics.

Unlike traditional non-idler-equipped designs, we can tune anti-squat levels with virtually no pedal kickback.

Suspension remains fully active during pedalling efforts and, gives the bike perfect traction on technical climbs.

ONE RIDE

At our core, is a philosophy that everyone who rides our bikes should get the same great ride characteristic. We sweat the details and put extra effort into our geometry and sizing to embody this philosophy. These small but important details ensure riders feel comfortable and confident on our bikes.



WEIGHT BALANCE

The term weight balance refers to the relationship between the rear-center and front-center measurements and the resultant position of the rider's center of gravity between the tire contact patches. Weight balance is a major contributing factor to a bike's overall ride feel and trail characteristics. If the rear-center of a bike remains the same while the front-center changes with size, then each size of bike will have a different weight distribution and different trail characteristics. We use scaled front and rear-center measurements that maintain the intended weight balance across all sizes. As a result, the rider's weight is distributed evenly across tire contact patches ensuring all riders experience the same intended trail characteristics regardless of size.

PROPORTIONAL SIZING

There is a lot of talk about balanced geometry and proportional geometry, but only a little action when it comes to truly offering proportional rear-center measurements across all sizes of bikes. At Forbidden, to deliver a consistent ride experience across all sizes, we use a scaled rear-center measurement for each individual frame size. We are the only brand to have true proportional sizing. Our actual seat angles change with each size and get steeper as frame size increases. Ensuring taller riders have a more comfortable seated position than our competitors. Our commitment to a better fit for all riders also led us to larger than normal differences in head tube length to better suit each end of the size range. We sweat the details to deliver a ride experience that conjures confidence and comfort for riders of all sizes and statures.



FORBIDDEN BIKE CO.
forbiddenbike.com

contact@forbiddenbike.com
Unit #1 - 4640 Cumberland Rd.
Cumberland, BC Canada V0R 1S0

